

EX100/200 Series

Insertion Magnetic Flow Meter Instructions



EX11x
EX21x



EX15x
EX25x

General Information

General InformationPage 3
 Features.....Page 3
 SpecificationsPage 4

Installation

Positioning the MeterPage 5
 Immersion.....Page 5
 Chemical Injection or FertigationPage 5
 EX11x/21x Installation.....Page 6
 EX15x/25x Installation.....Page 6
 Depth Setting.....Page 7
 Pipe Wall Thickness.....Page 8
 Straight Pipe RecommendationsPage 9
 Full Pipe Recommendations.....Page 10

Electrical Connections

General Electrical Guidelines.....Page 11
 Power.....Page 11
 Output.....Page 11
 Grounding Guidelines.....Page 11

Connection Diagrams

Counter or PLC.....Page 12
 A055 4-20 mA OutputPage 12
 FT520 ControllerPage 12
 FT430/440 Display & Proportional FeedPage 13
 FT440 & 4-20 mA Output.....Page 13
 Dual FT430/440 DisplaysPage 14

Operation & Maintenance

Zero AdjustmentPage 15
 Minimum FlowPage 15
 Filtering.....Page 15
 Electrode Coating.....Page 15
 Calibration ("K-Factor").....Page 15
 Flow Rates in Gallons Per Minute.....Page 15
 Parts ListPage 16

Troubleshooting

ProblemsPage 17
 Probable Causes.....Page 17
 Things to TryPage 17

Warranty

Seametrics Limited WarrantyPage 18

The **EX100/200-Series** are adjustable depth insertion magmeters that fit 3" to 48" pipe (up to 72" optional). The complete lack of moving parts of the EX100/200-Series is the source of its reliability. Brass and stainless steel models withstand a variety of temperature, pressure, and chemical conditions. The EX-Series has no rotor to stop turning in dirty water and there are no bearings to wear out. Like all magmeters, when used in chemical injection applications, these meters should be installed upstream of the chemical line (or far enough downstream to allow complete mixing of fluids before the meter). Adapters mate with standard 1-1/2" (11x/21x) or 2" (15x/25x) FNPT threaded fittings such as saddles and weldolets which may be purchased either locally or from Seametrics.

A rapidly reversing magnetic field is produced in the lower housing. As the fluid moves through this field, a voltage is generated that is measured and translated into a frequency signal proportional to flow rate. This square wave signal can be sent directly to a PLC or other control or can be

converted using any of the Seametrics family of indicators and converters.

A modular system of electronics can be installed directly on the flow sensor or mounted remotely. The FT430 (externally powered with pulse) and the FT440 (loop powered), both provide digital rate and total displays, as well as a programmable pulse; the FT440 also provides a 4-20 mA analog output. Built-in data logging is available as an option for secure flow logging.

The "hot-tap" models (EX15x/25x) can be installed or serviced without shutting down the line by means of a 2" full-port isolation valve that comes with a nipple for installation on the pipe fitting; a bronze ball valve is standard, with a 316 stainless steel valve option if needed. In most circumstances, no special tool is required.

Reverse flow output and immersibility are optional.

Features

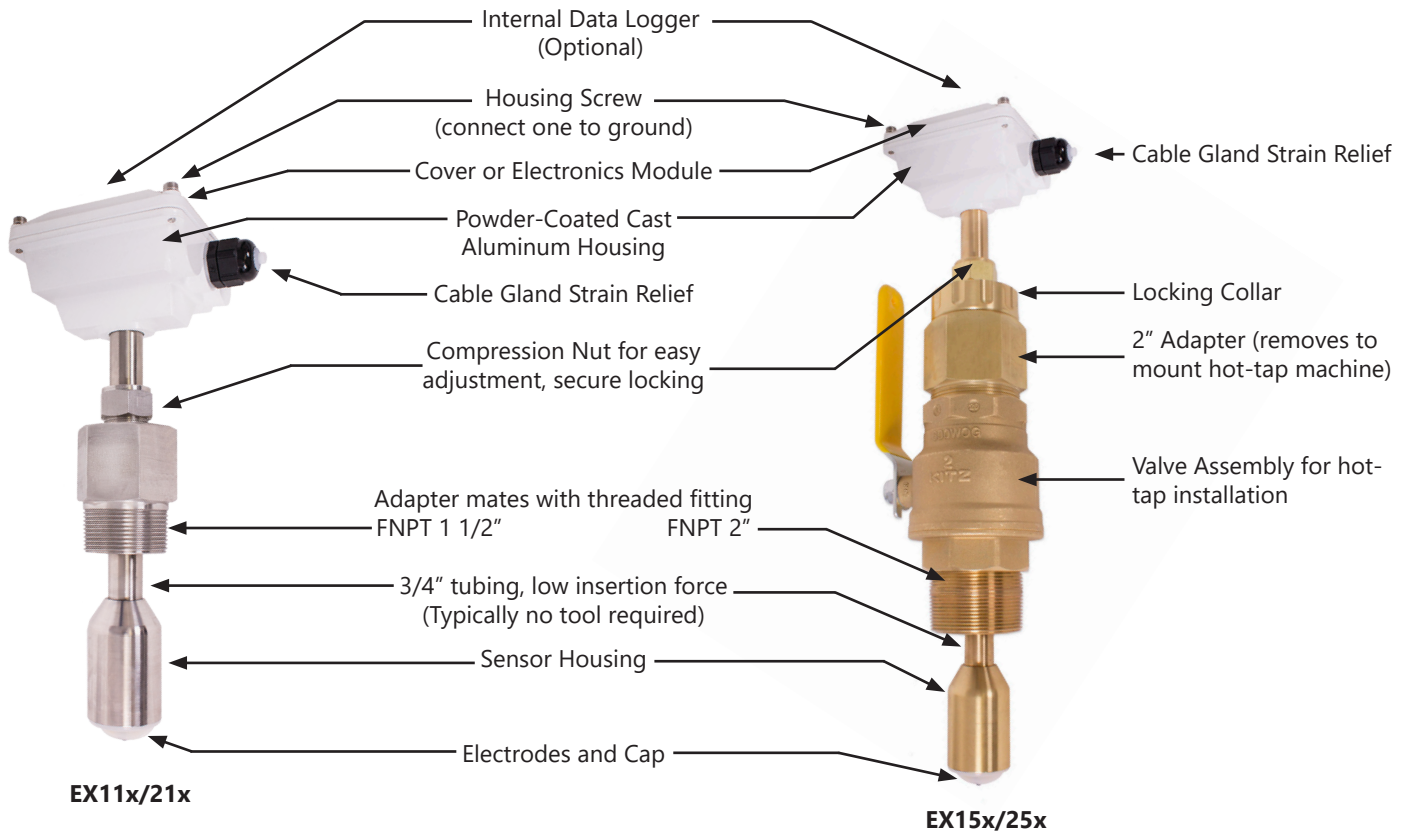

Specifications*

Pipe Size	3" to 48" (up to 72" optional)	
Power	Full Power: 12 - 24 Vdc, 250mA	Low Power: 12 - 24 Vdc, 40mA average with 250mA peaks
Materials	Housing	Powder-coated cast aluminum
	Tubing/Fitting/Sensor Housing	Brass or 316 Stainless Steel
	Electrodes	Hastelloy
	Electrode Cap	PVDF
	O-Ring (15x/25x only)	EPDM
	Valve Assembly (15x/25x only)	Bronze (stainless optional) with bronze ball valve
Fitting Size Required	11x/21x: 1.5" FNPT	15x/25x: 2" FNPT
Maximum Pressure	200 psi (14 bar)	
Temperature	Ambient	0° to 160° F (-17° to 72° C)
	Fluid	32° to 200° F (0° to 93° C)
Minimum Conductivity	20 microSiemens/cm	
Flow Velocity	0.28 - 20 ft/sec (0.08 - 6.09 m/sec)	
Accuracy	± 1% of full scale	
Output	Square wave pulse, opto-isolated, 500 Hz @ 20 ft/sec 6 mA max, 30Vdc forward flow standard; reverse flow optional	
Empty Pipe Detection	Software, defaults to zero flow	
Cable	Standard 18' (6m), #22 shielded twisted pair, 4-conn. Max. cable run at 24 Vdc = 1000' (300m); at 12 Vdc = 500' (150m). For other circumstances, contact the factory.	
Environmental	See meter mounted electronic specification for rating.	
Regulatory	CE Mark (applies to full power sensor only configuration and full power FT 430/440 mounted configurations). Certified to NSF/ANSI standard 61 and NSF 372 (Stainless only)	

*Specifications subject to change • Please consult our website for current data (seametrics.com).

Positioning the Meter

For best results, the EX100/200 sensor should be installed with at least ten diameters of straight pipe upstream and five downstream. Certain extreme situations such as partially-opened valves are particularly difficult and may require more straight diameters upstream (see page 9 for straight pipe recommendations).

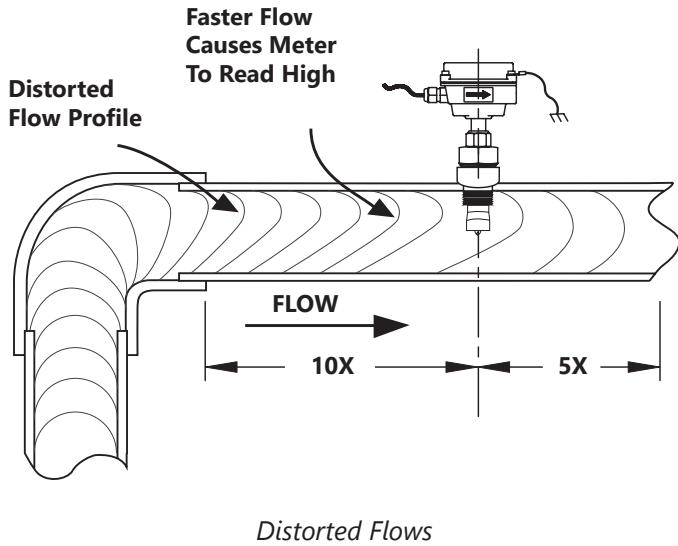

Distorted Flows

Horizontal (3 o'clock or 9 o'clock position) is the preferred installation orientation, since it improves low-flow performance and avoids problems with trapped air and sediment. (See Orienting the Meter diagram below.) Bottom (6 o'clock) and top (12 o'clock) installations are acceptable if required by the piping layout.

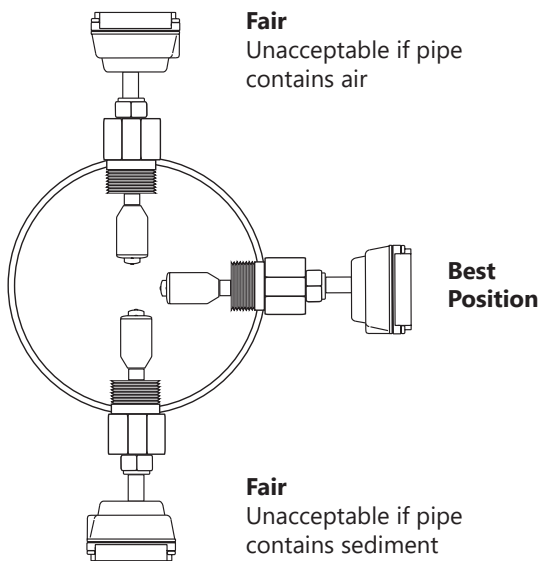

Orienting the Meter

Immersion

The 100/200-Series sensors are not designed for underwater operation. Even occasional immersion can cause damage. If occasional immersion, such as when a vault floods, then the -40 option, (immersion) is recommended.

Chemical Injection or Fertigation

When a magmeter is used in a chemical injection application (including fertigation), the chemical line must be placed downstream of the magmeter OR far enough upstream for complete mixing to occur before the fluid reaches the meter. When unmixed chemical or fertilizer alternates with water passing through the meter, the rapid changes in conductivity may cause sudden spikes and drops in the meter's reading, resulting in inaccurate measurement. The magmeter will restabilize, however, with a steady flow of fluid of uniform conductivity.

Caution: In chemical injection or fertigation applications, install chemical line downstream of magmeter, or far enough upstream to allow complete mixing of fluids before the meter.

Caution: These flow sensors are not recommended for installation downstream of a boiler feedwater pump where installation fault may expose the flow sensor to boiler pressure and temperature. Maximum recommended temperature is 200°F.

EX11x/21x Installation

Fitting Installation. EX11x/21x adapters mate with a 1-1/2" female NPT pipe thread adapter fitting. Any fitting that provides the matching NPT female thread may be used. Installation procedure compensates for fitting height differences. Cut a minimum 1-3/4" hole in the pipe. If possible, measure the wall thickness and write it down for use in depth setting. Then install the threaded fitting (saddle, weldolet, etc.) on the pipe.

Meter Installation. Loosen the compression nut so that the adapter slides freely. Pull the meter fully upward and finger-tighten the compression nut. Using a thread sealant, install the adapter in the pipe fitting. Do not overtighten. Now loosen the compression nut, lower the meter to the appropriate depth setting (see diagram and instructions that follow). Be sure flow is in the direction of the arrow on the housing. Fully tighten compression nut.

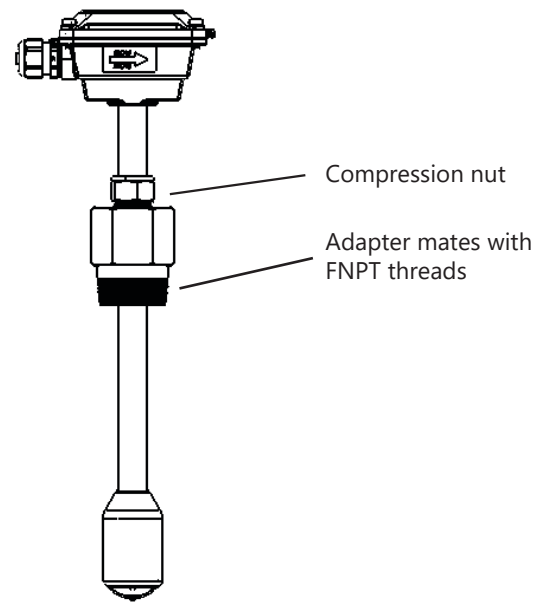

EX15x/25x Installation

'Hot tap' EX meters are designed so they can be installed and serviced without depressurizing the pipe.

Fitting Installation. The EX15x/25x adapters mate with a 2" FNPT threaded fitting for compatibility with the 2" isolation valve. Any fitting that provides matching NPT female thread may be used. The installation procedure compensates for differences in fitting height.

If initial installation is performed on an unpressurized pipe, cut a minimum 1-3/4" hole in the pipe. If possible, measure the wall thickness and write it down for use in depth setting. Then install the threaded fitting (saddle, weldolet, etc.) on the pipe.

If it is necessary to do the initial installation under pressure, any standard hot tap drilling machine with 2" NPT adapter, such as a Transmate or a Mueller, can be used. Ordinarily, it is not necessary to use an installation tool, due to the small diameter tube the meter can be installed by hand at all but the highest pressures.

Meter Installation. Remove the sensor unit from the valve assembly. Using a thread sealant, install the valve assembly on the pipe fitting. If the initial installation is a pressure ("hot") tap, remove the 1-1/2" x 2" adapter bushing at the back of the valve. Thread the tapping machine on, open the valve, and tap using a minimum of 1-3/4" or maximum 1-7/8" cutter. After retracting the machine and closing the valve, reinstall the flow sensor. When the sensor is secure, open the valve and adjust depth setting (see diagram and instructions that follow). Be sure flow is in the direction of the arrow on the housing. Fully tighten locking collar and compression nut.

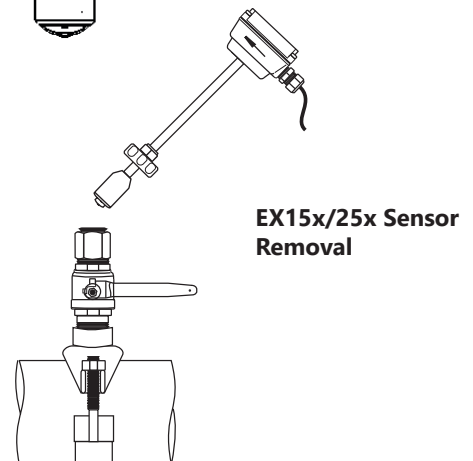
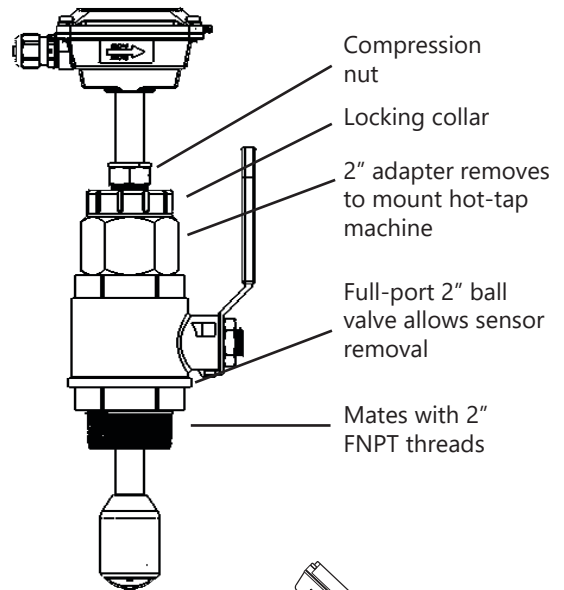

Depth Setting

It is important for accuracy that the sensor be inserted to the correct depth into the pipe.

1. Please visit **seametrics.com** and select the **K-factor Calculator** located at the bottom of the home page to find dimension D (insertion depth setting)*.
2. Measuring from the outside of the pipe to the joint in the housing, as shown in the diagram, adjust the sensor to Dimension D and hand-tighten compression nut.
3. Align the conduit housing with the centerline of the pipe, as shown. Be sure the arrow on the housing points in the direction of flow.

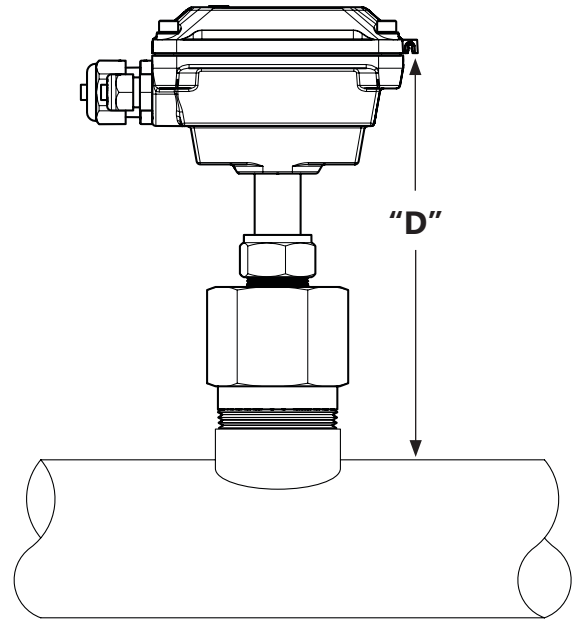
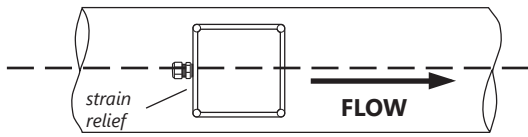

Proper Depth Setting

4. Check Dimension D one more time.
5. Fully tighten the compression nut.

Record your settings. Once you have the meter set up and operational, it is important to record you meter settings and save them future reference.

K-Factor _____

Insertion Depth (Dim. D) _____



Caution! Never attempt to remove a flow sensor when there is pressure in the pipe unless it is specifically designed for hot tap installation and removal. Loosen the compression nut slowly to release any trapped pressure. If fluid sprays out when removing the sensor, stop turning and depressurize the pipe. Failure to do so could result in the sensor being thrown from the pipe, resulting in damage or serious injury.

* For pipe sizes larger than 50", please consult factory.

Pipe Wall Thickness

Nominal Pipe Size*													
	3"	4"	6"	8"	10"	12"	14"	16"	18"	20"	24"	30"	36"
Schedule 40	0.216	0.237	0.280	0.322	0.365	0.406	0.438	0.500	0.562	0.593	0.687	--	--
Schedule 80	0.300	0.337	0.432	0.500	0.593	0.687	0.750	0.843	0.937	1.031	1.218	--	--
Stainless Steel (10S)	0.120	0.120	0.134	0.148	0.165	0.180	0.188	0.188	0.188	0.218	0.250	0.312	0.312
Stainless Steel (40S)	0.216	0.237	0.280	0.322	0.365	0.375	0.375	0.375	0.375	0.375	0.375	0.375	0.375
Copper Tubing (Type L)	0.090	0.100	0.140	0.200	0.250	0.280	--	--	--	--	--	--	--
Copper Tubing (Type K)	0.109	0.134	0.192	0.271	0.338	0.405	--	--	--	--	--	--	--
Brass Pipe	0.219	0.250	0.250	0.312	0.365	0.375	--	--	--	--	--	--	--
Duct. Iron (Class 52)	0.280	0.290	0.310	0.330	0.350	0.370	0.390	0.400	0.410	0.420	0.440	0.470	0.530

* Call factory for larger pipe sizes.



Caution: These flow sensors are not recommended for installation downstream of a boiler feedwater pump where installation fault may expose the flow sensor to boiler pressure and temperature. Maximum recommended temperature is 200°F.

Straight Pipe Recommendations (X = diameter)

Reduced Pipe

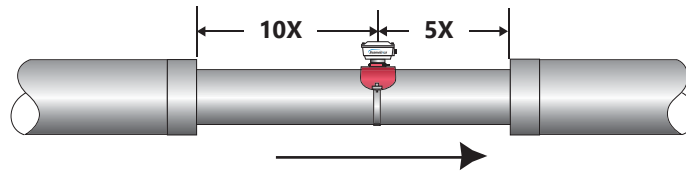

Two Elbows In Plane

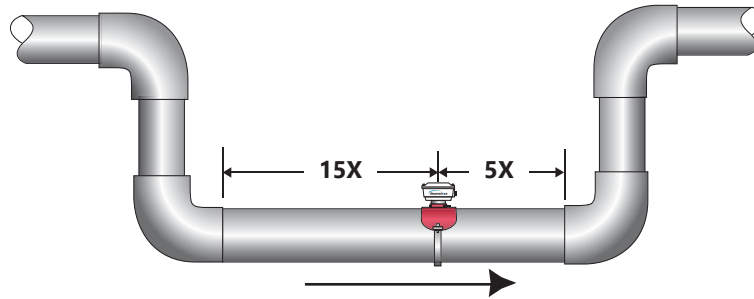

Two Elbows, Out Of Plane

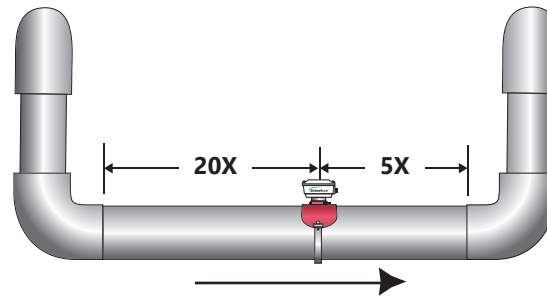

Expanded Pipe

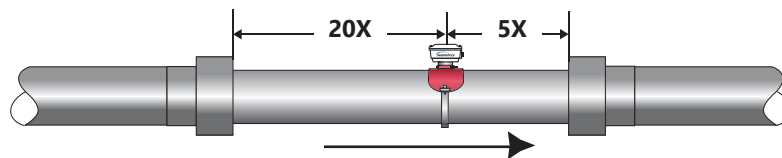

Spiral Flow

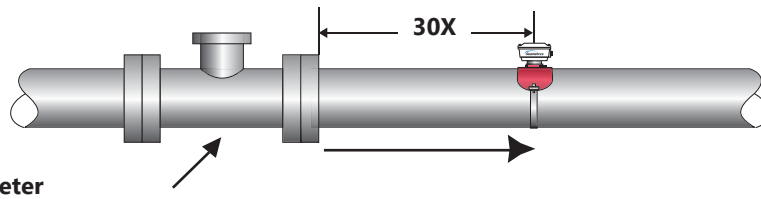

Propeller Meter

Swirling Flow

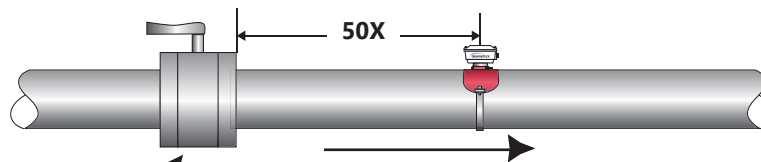

**Partially Open
Butterfly Valve**

Full Pipe Recommendations

Possible Problem

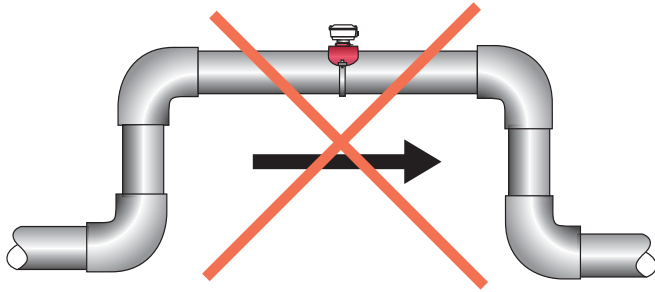

Allows air pockets to form at sensor

Better Installation

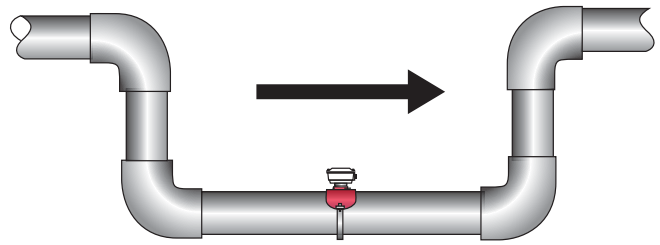

Ensures full pipe

Possible Problem

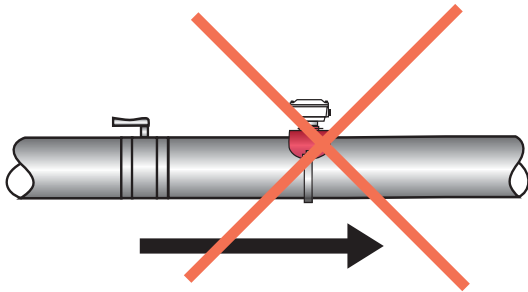

Post-valve cavitation can create air pocket

Better Installation

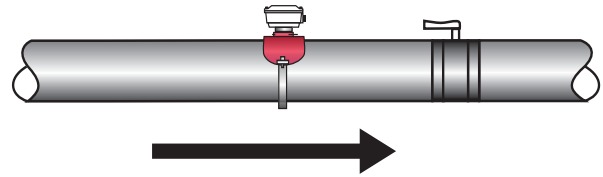

Keeps pipe full at sensor

Possible Problem

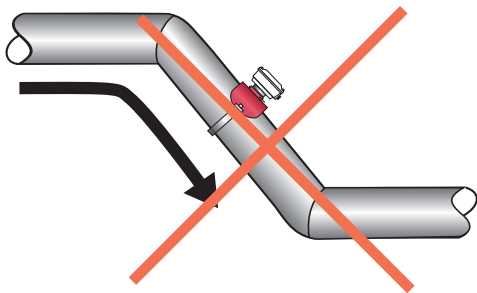

Air can be trapped

Better Installation

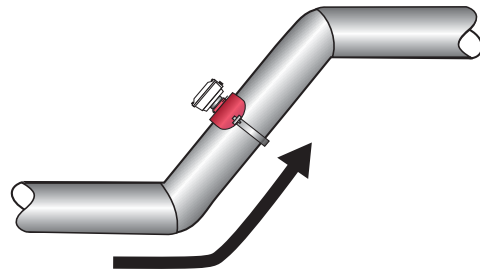

Allows air to bleed off

Possible Problem

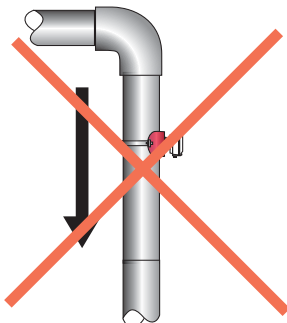

Air can be trapped

Better Installation

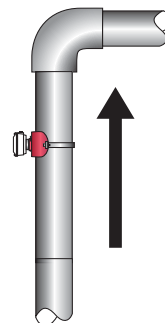

Allows air to bleed off

General Electrical Guidelines

- Whenever possible avoid running control cables in the same conduit with or bundled with AC power.
- Using shielded cable, be sure to connect shield to ground at power supply end of the cable. Do not connect other end of shield.
- Avoid routing flow sensor cables in close proximity to a variable frequency drive.
- Recommended power and output wiring is shielded twisted pair 18-22 AWG control cable.
- Recommended voltage is 12-24 Vdc. Note that unregulated power supplies can vary from nameplate voltage by a considerable amount, especially with AC line voltage fluctuation. Therefore 24V power supplies must be regulated.

See the Connections diagrams on the following pages for the appropriate terminals.

Power

A 12 - 24 Vdc power supply capable of at least 250 mA current output is needed.

Output

The standard output is pulses with flow in the forward direction (Reverse flow output is optional [-15]). Electrically it is an open collector opto isolated switch. The output is not internally powered.

Note: This output is limited to 6 mA at 30 Vdc maximum.



Caution: The EX100/200-Series have strong start and run currents. When using solar panels and VRSLA batteries as a power source, use caution to insure the EX-series sensor has the -50 Low-power Option and that all Seametrics products on the power circuit receive sufficient voltage and current under all conditions. Failure to do so will lead to unreliable operation and possible damage to the unit/s. Please reference the technical bulletin, 'Solar and Battery-Power Guidelines' available on our website: www.seametrics.com

Grounding Guidelines:

For best results, use a good quality earth ground, such as metallic water piping or a driven ground, to ensure a good connection to earth ground and good noise suppression.

If the flow sensor is installed in metallic piping, for optimum connection clamp wire to the piping a short distance to one side of the flow sensor using an electrical grounding clamp. Connect the wire to the earth ground and to one of the housing screws.

For Non-Metallic Pipe: Connect one to the housing screws by wire to a good earth ground, such as metallic water piping or a rod driven into the ground.

EX meters are usually unaffected by moderate levels of electrical noise. In some applications performance may be improved by taking the following steps:

- Use shielded twisted pair cable (Belden 8723 or equivalent above ground or Alpha 35482 or equivalent burial).
- Clamp a ferrite bead (Steward 28A2029-OAO or equivalent) on meter signal/power wire within 3/4" of the meter strain relief (tape or tie wrap in place if necessary). See diagram below.
- IMPORTANT - Connect the cable shield ground wire to ground, ONLY at power supply end of cable.

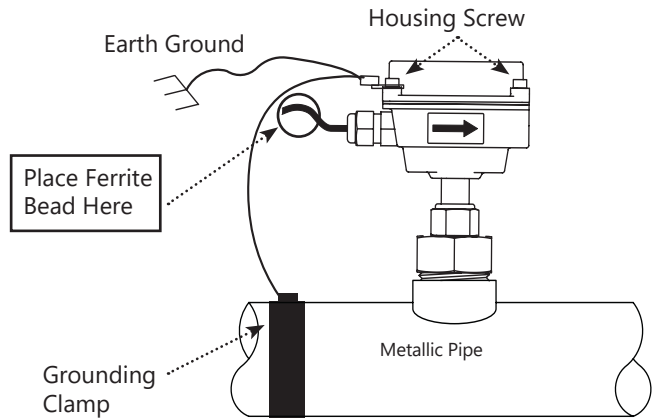

Counter or PLC

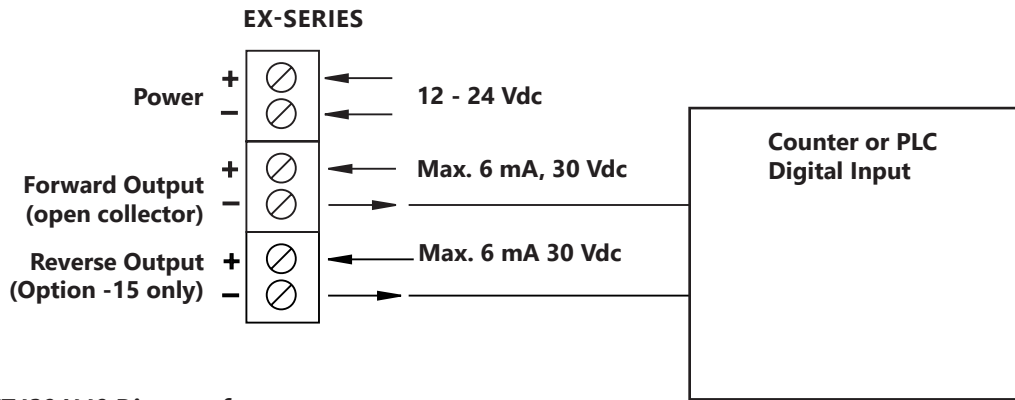

See Dual FT430/440 Diagram for an example of bidirectional connections.

FT520 Controller

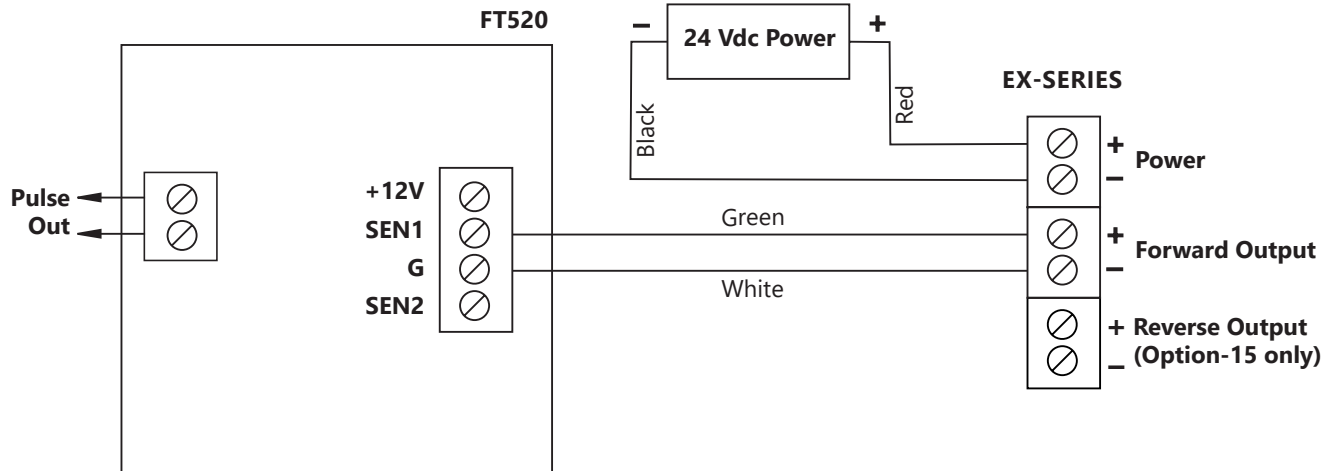

See Dual FT430/440 Diagram for an example of bidirectional connections.

FT430/440 Display and Proportional Feed

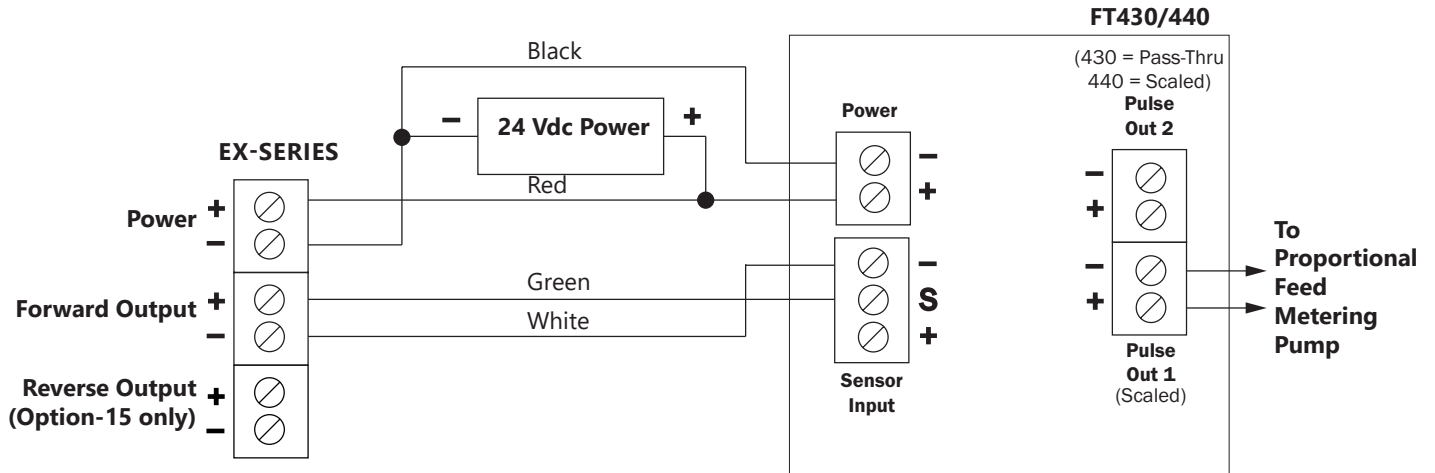

See Dual FT430/440 Diagram for an example of bidirectional connections.

FT440 DISPLAY AND 4-20 mA Output

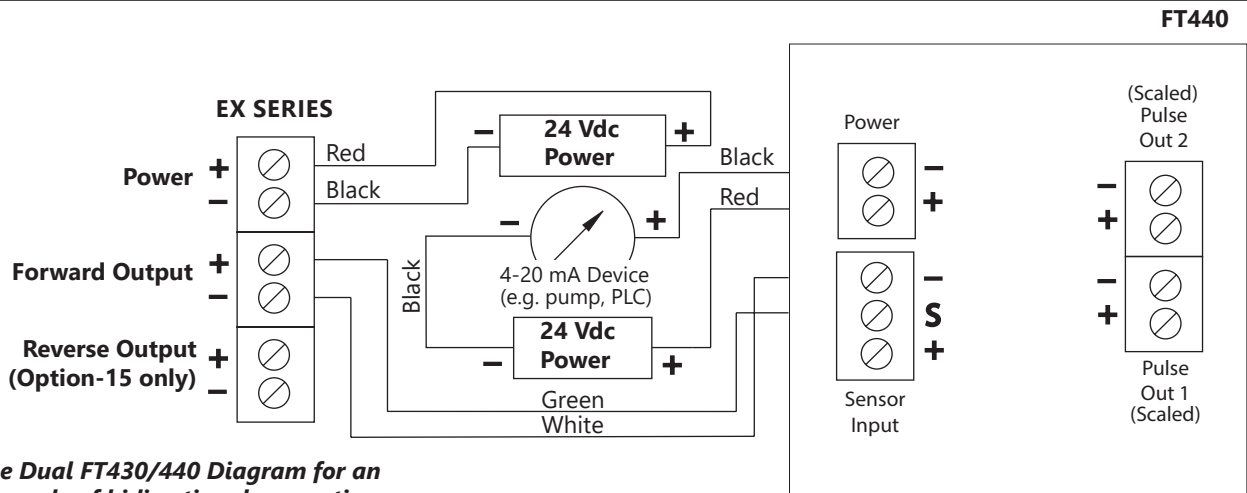

See Dual FT430/440 Diagram for an example of bidirectional connections.

Dual FT430/440 Displays (Example of Bidirectional Connection)

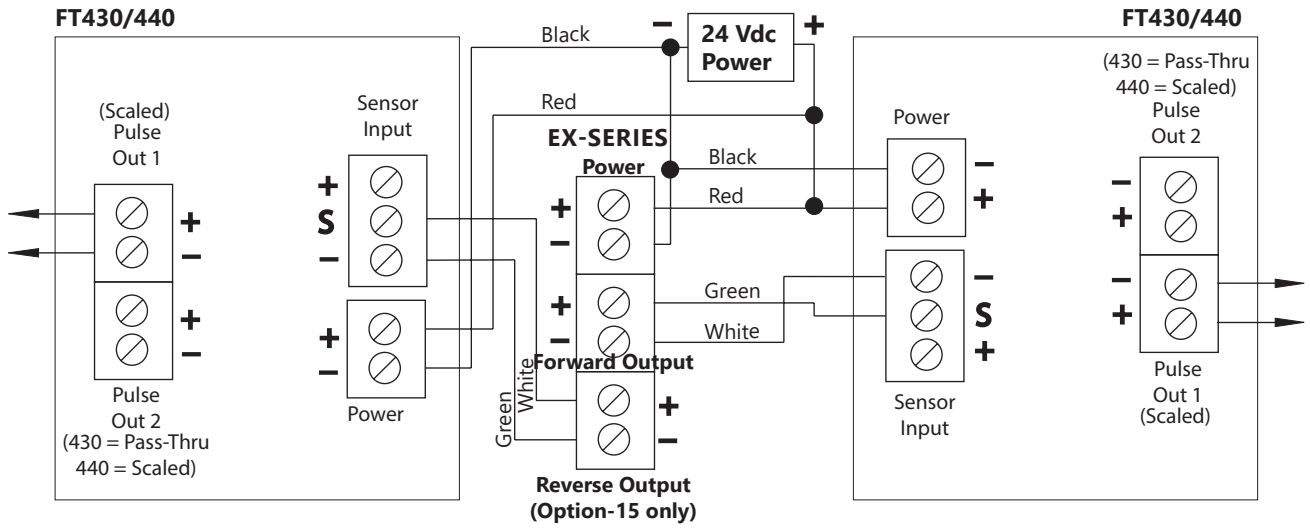

Zero Adjustment

When the EX100/200-Series meter is powered up and there is no flow, there should be no output pulses (or, if connected to the FT430/440, flow rate should read "0"). If there are pulses, it may be necessary to adjust the flow meter under no-flow conditions after it has been installed. **This should only be done if the indicated flow is low, near the lower cutoff.**

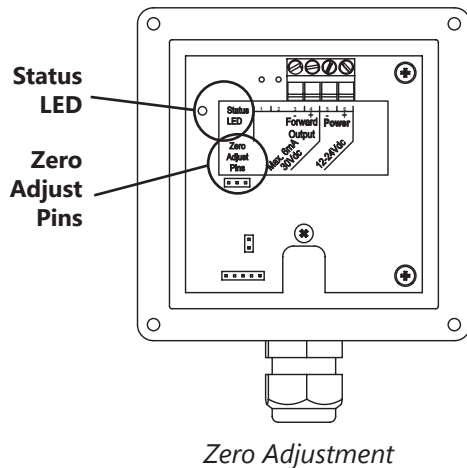

To perform the adjustment, after determining that there is a full pipe with no flow, short between the two pins marked "Zero Adjust". A red LED light will come on for approximately 50 seconds and then go out. The zero adjustment is completed.

Minimum Flow

As with any other flow sensor, there is a rate below which the EX100-Series sensor cannot read. Check the table below for the minimum flow rate detectable by the sensor for a given pipe size.

Presence of Flow Indication. To assist in troubleshooting, the "Status LED" has two blinking modes in normal operation. When there is no flow detectable by the meter (below minimum threshold) the LED blinks every 8.0 seconds. When there is detectable flow, the same indicator blinks every 3.0 seconds (Pulses are being output when indicator is blinking every 3 seconds).

Flow Rates (in gallons per minute)

Feet Per Second	Nominal Pipe Size													
	3"	4"	6"	8"	10"	12"	14"	16"	18"	20"	24"	30"	36"	48"
Min 0.28	6	11	25	44	69	99	134	175	222	274	395	617	888	1,580
Max 20.0	440	783	1,762	3,133	4,895	7,050	9,596	12,533	15,863	19,584	28,200	44,064	63,452	112,804

Filtering

The software of the EX100/200-Series filters out electrical noise and averages sudden variations in the flow to smooth the output. It takes a matter of seconds for the flow sensor to get up to full output when it is powered up or when flow begins.

Electrode Coating

Grease or other adhering, non-conductive materials can stop flow detection if the electrodes become heavily coated. To clean the electrodes, remove the sensor from the pipe and gently scrub the electrodes (three silver bumps) on the reading face of the flow sensor. A mild soap (dishwashing liquid for example) can be used to aid the cleaning process.

Calibration ("K-Factor")

In order to properly process pulses from the flow sensor, a number must be entered into the control to which the sensor is connected. This number, called the K-factor, is the number of pulses the sensor puts out per unit of fluid passing through the pipe. It is normally provided for Seametrics sensors in pulses per gallon, and can be ascertained by using the "K-Factor Calculator" on the Seametrics website. These numbers are based on extensive testing, which has shown close agreement among different EX sensors in the same installation. Typically, most K-factor error can be attributed to installation variables, such as depth setting and fitting configuration.

Using the K-Factor Calculator:

Go to seametrics.com and select the **K-factor Calculator** located at the bottom of the home page*.

1. Select your meter.
2. Choose units.
3. Input external pipe diameter (measure) and wall thickness (measure, or look-up in Pipe Wall Thickness table on page 8 of this manual).
4. Press Calculate to determine your K-factor. **(NOTE: Dimension D is also calculated.)**
5. Enter your K-factor into your controller.

**For pipe sizes larger than 50", please consult factory.*

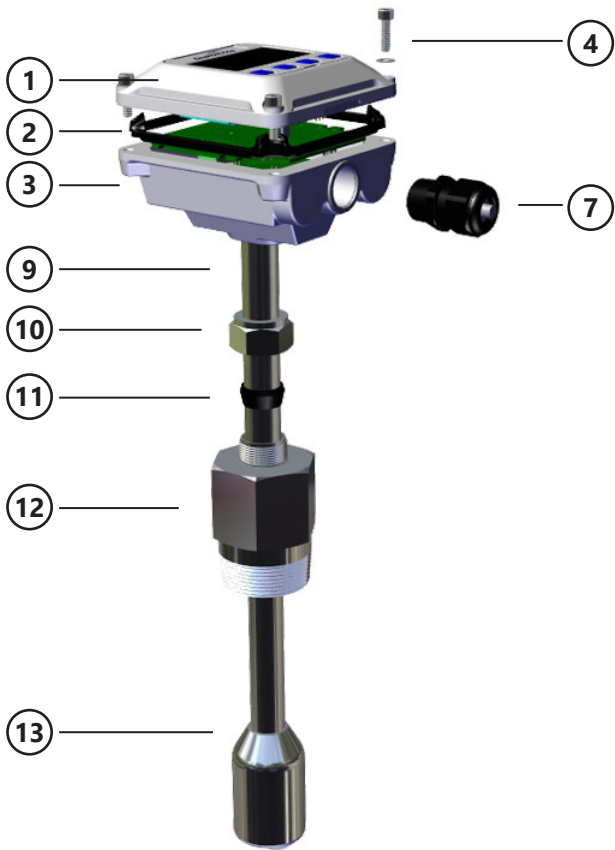

EX 11x/21x Parts

1	Upper housing/ electronics	Contact service representative for your specific model
2	Housing gasket/seal	102025
3	Lower housing	Not field replaceable
4	Housing screw/washer kit (4 each)	100414
7	Strain relief kit, large (includes 1)	101850
9	Tube	Not field replaceable
10	Compression nut	100064 (brass) 100084 (ss)
11	Compression ferrule	100358
12	Adapter	100845 (brass) 100846 (ss)
13	Sensor assembly	Not field replaceable

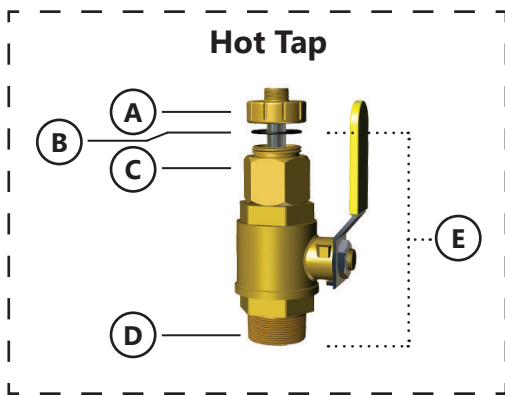

EX 15x/25x Parts (Hot Tap)

All parts are the same except those below, which replace #12

A	Locking collar	100061 (brass) 100116 (ss)
B	Adapter fitting o-ring	100345 (EPDM)
C	Adapter, hot tap	100384 (brass) 100385 (ss)
D	Nipple, 2 inch	100066 (brass) 100103 (ss)
E	Valve assembly (includes valve plus B, C, & D above)	100069 (brass) 100119 (ss)

Problem	Probable Cause	Try...
No pulse output	Unit not grounded Below minimum flow cutoff Flow reversed Output connections reversed Pipe not full Excessive electrical noise No power Power reversed Fluid conductivity <20 $\mu\text{S}/\text{cm}$	Connect to earth ground. Check the Presence of Flow LED (see page 15). Note flow direction arrow, reverse direction to meter. Change output connections. Check plumbing. Check for proper electrical wiring. Check for power across power input terminals. Reverse connections Select another flow meter.
Output pulses incorrect	Missing or incorrect ground wire Incorrect depth setting Fluid conductivity <20 $\mu\text{S}/\text{cm}$ Empty pipe Not enough straight pipe Excessive electrical noise	Check for proper ground. Check depth setting (see page 7). Select another flow meter. Check for full pipe or install meter in vertical position. Check for air pockets or turbulence. Refer to Installation section earlier in this manual. Check for proper electrical wiring.
Jumpy readings	Rapidly changing conductivity (in chemical injection or fertigation applications).	Install chemical injection line downstream of magmeter (or far enough upstream to allow complete mixing of fluids before meter)

The limited warranty set forth below is given by Seametrics, with respect to Seametrics brand products purchased in the United States of America.

Seametrics warrants that products manufactured by Seametrics, when delivered to you in new condition in their original containers and properly installed, shall be free from defects in material and workmanship. **Seametrics products are warranted against defects for a minimum period of two (2) years from date of installation, unless otherwise specified, with proof of install date. If no proof of install date can be provided, warranty period will be two (2) years from date of shipment from Seametrics, as defined on Seametrics' invoice.** Seametrics' obligation under this warranty shall be limited to replacing or repairing the part or parts, or, at Seametrics' option, the products, which prove defective in material or workmanship. The following are the terms of Seametrics' limited warranty:

- a. Buyer must give Seametrics prompt notice of any defect or failure and satisfactory proof thereof.
- b. Any defective part or parts must be returned to Seametrics' factory or to an authorized service center for inspection.
- c. Buyer will prepay all freight charges to return any products to Seametrics' factory, or another repair facility, as designated by Seametrics.
- d. Defective products, or parts thereof, which are returned to Seametrics and proved to be defective upon inspection, will be repaired to factory specifications.
- e. Seametrics will deliver repaired products or replacements for defective products to the buyer (ground freight prepaid) to the destination provided in the original order.
- f. Products returned to Seametrics for which Seametrics provides replacement under this warranty shall become the property of Seametrics.
- g. This limited warranty covers all defects encountered in normal use of Seametrics products, and does not apply to the following cases:
 - i. Loss of or damage to Seametrics product due to abuse, mishandling, or improper packaging by buyer
 - ii. Failure to follow operating, maintenance, or environmental instructions prescribed in Seametrics' instruction manual
 - iii. Products not used for their intended purpose
 - iv. Alterations to the product, purposeful or accidental
 - v. Electrical current fluctuations
 - vi. Corrosion due to aggressive materials not approved for your specific product
 - vii. Mishandling, or misapplication of Seametrics products
 - viii. Products or parts that are typically consumed during normal operation
 - ix. Use of parts or supplies (other than those sold by Seametrics) which cause damage to the products, or cause abnormally frequent service calls or service problems
- h. A new warranty period will be established for repaired products, or products replaced during the original warranty period.
- i. In the event that equipment is altered or repaired by the buyer without prior written approval by Seametrics, all warranties are void. Damage caused by equipment or accessories not manufactured by Seametrics may void the product's warranty.
- j. SOFTWARE: The Seller grants the user a non-exclusive license to use Seametrics' software, according to the following limitations and conditions:
 - i. The user may install the software on one or more desktop or laptop computers.
 - ii. All title and intellectual rights to the software are owned by Seametrics.
 - iii. No copies may be made or distributed except as described above.
 - iv. The user may not modify or reverse-engineer the software.

THE FOREGOING WARRANTY IS IN LIEU OF ALL OTHER WARRANTIES, WHETHER ORAL, WRITTEN, EXPRESSED, IMPLIED OR STATUTORY. NO IMPLIED WARRANTY, INCLUDING ANY IMPLIED WARRANTY OF MERCHANTABILITY OR FITNESS FOR A PARTICULAR PURPOSE, APPLIED TO THE PRODUCTS AFTER THE APPLICABLE PERIOD OF THE EXPRESS LIMITED WARRANTY STATED ABOVE, AND NO OTHER EXPRESS WARRANTY OR GUARANTY, EXCEPT AS MENTIONED ABOVE, GIVEN BY ANY PERSON OR ENTITY WITH RESPECT TO THE PRODUCTS, SHALL BIND SEAMETRICS. SEAMETRICS SHALL NOT BE LIABLE FOR LOSS OF REVENUES, OR PROFITS, OR INCONVENIENCES, EXPENSE FOR SUBSTITUTE EQUIPMENT OR SERVICE, STORAGE CHARGES, LOSS OF DATA, OR ANY OTHER SPECIAL, INCIDENTAL, OR CONSEQUENTIAL DAMAGE CAUSED BY THE USE OR MISUSE OF, OR INABILITY TO USE THE PRODUCTS, REGARDLESS OF THE LEGAL THEORY ON WHICH THE CLAIM IS BASED, AND EVEN IF SEAMETRICS HAS BEEN ADVISED OF THE POSSIBILITY OF SUCH DAMAGES. IN NO EVENT SHALL RECOVERY OF ANY KIND AGAINST SEAMETRICS BE GREATER IN AMOUNT THAN THE PURCHASE PRICE OF THE PRODUCT SOLD BY SEAMETRICS AND CAUSING THE ALLEGED DAMAGE. WITHOUT LIMITING THE FOREGOING, YOU ASSUME ALL RISK OF LIABILITY FOR LOSS, DAMAGE, OR INJURY TO YOU AND YOUR PROPERTY AND TO OTHERS AND THEIR PROPERTY ARISING OUT OF USE OR MISUSE OF, OR INABILITY TO USE THE PRODUCTS NOT CAUSED DIRECTLY BY THE NEGLIGENCE OF SEAMETRICS.

SOME STATES DO NOT ALLOW LIMITATIONS ON THE DURATION OF AN IMPLIED WARRANTY, SO THE ABOVE LIMITATIONS MAY NOT APPLY TO YOU. SIMILARLY, SOME STATES DO NOT ALLOW THE EXCLUSION OR LIMITATIONS OF CONSEQUENTIAL DAMAGE, SO THE ABOVE LIMITATION OR EXCLUSION MAY NOT APPLY TO YOU. THIS LIMITED WARRANTY GIVES YOU SPECIFIC LEGAL RIGHTS; HOWEVER, YOU MAY ALSO HAVE OTHER RIGHTS WHICH MAY VARY FROM STATE TO STATE.



Seametrics • 19026 72nd Avenue South • Kent, Washington 98032 • USA
(P) 253.872.0284 • (F) 253.872.0285 • 1.800.975.8153 • seametrics.com

LT-65200196r3.5 20210415
4/15/2021